

# Linear Single Cell Li-Ion Battery Charger IC for Portable Applications

## *Purpose*

The RT9536H is a fully integrated single cell Li-ion battery charger IC ideal for portable applications. This document explains the function and use of the RT9536H evaluation board (EVB), and provides information to enable operation, modification of the evaluation board and circuit to suit individual requirements.

## Table of Contents

Purpose .....	1
Introduction.....	2
Key Performance Summary Table .....	2
Bench Test Setup Conditions .....	3
Schematic, Bill of Materials & Board Layout .....	5
More Information.....	6
Important Notice for Richtek Evaluation Board .....	7

## Introduction

### General Product Information

The RT9536H is a fully integrated single cell Li-ion battery charger IC ideal for portable applications. The RT9536H optimizes the charging task by using a control algorithm including pre-charge mode, fast charge mode and constant voltage mode. The input voltage range of the VIN pin can be as high as 28V. When the input voltage exceeds the OVP threshold, it will turn off the charging MOSFET to avoid overheating of the chip.

In RT9536H, the maximum charging current can be programmed with an external resistor. For USB application, the user can set the current to 100mA/500mA through the EN/SET pin. For the factory mode, the RT9536H can allow 4.25V or 4.4V/2.3A power pass through to support system operation. It also provides a 50mA LDO to support the power of peripheral circuit. The internal thermal feedback circuit regulates the die temperature to optimize the charge rate for all ambient temperatures. The RT9536H provides protection functions such as under voltage protection, over voltage protection for VIN supply and thermal protection for battery temperature.

The RT9536H is available in a WDFN-10L 3x2 package to achieve optimized solution for PCB space and thermal considerations.

### Product Feature

- 28V Maximum Rating for DC Adapter
- Internal Integrated Power MOSFETs
- Support 4.25V or 4.4V/2.3A Factory Mode
- 50mA Low Dropout Voltage Regulator
- Status Pin Indicator
- Programmer Charging Current
- Under Voltage Lockout
- Over Voltage Protection
- Thermal Feedback Optimized Charge Rate
- RoHS Compliant and Halogen Free

### Key Performance Summary Table

Key Features	Evaluation Board Number : PCB053_V1
Default Input Voltage	5V
Max Output Current	1.2A
Default Output Voltage	4.25V
Default Marking & Package Type	RT9536HGQW, WDFN-10L 3x2

## Bench Test Setup Conditions

### Headers Description and Placement

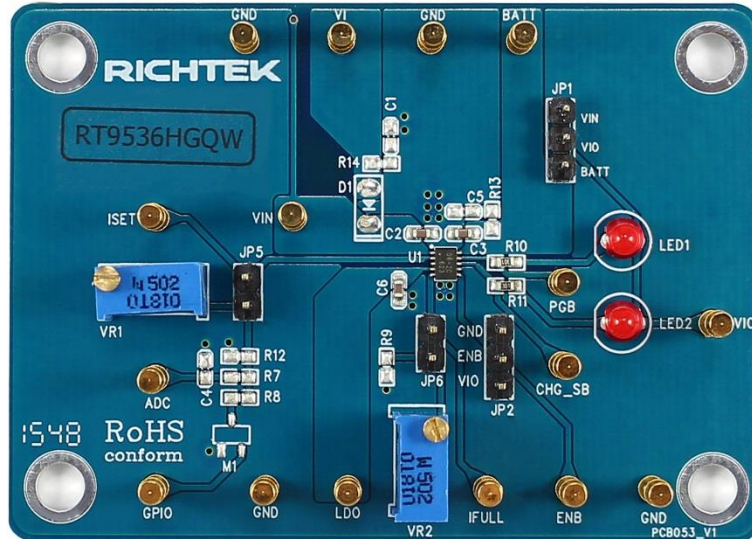

Please carefully inspect the EVB IC and external components, comparing them to the following Bill of Materials, to ensure that all components are installed and undamaged. If any components are missing or damaged during transportation, please contact the distributor or send e-mail to [evb\\_service@richtek.com](mailto:evb_service@richtek.com).

### Test Points

The EVB is provided with the test points and pin names listed in the table below.

Test point/ Pin name	Signal	Comment (expected waveforms or voltage levels on test points)
<b>VIN</b>	Input voltage	Power input. Support 4.75V to 5.5V Input Voltage.
<b>GND</b>	Ground	Ground.
<b>LDO</b>	LDO output	LDO Output (4.9V). This pin provides 50mA output current.
<b>CHGSB</b>	Indicator Output for Charging Status	The CHGSB pin indicate the charger status. During the charging process, the CHGSB pin is pulled low. When the charger is under charge done condition or abnormal condition, the CHGSB will be high impedance.
<b>PGB</b>	Indicator Output for Power Status	The PGB pin indicates the input power status at VIN pin. When the input power is normal, the PGB pin is pulled low.
<b>BATT</b>	Battery Charge Current Output	Charger output for battery.
<b>ENB</b>	Enable Control Input	Enable and Operation Mode and V <sub>OUT</sub> Regulation Voltage Setting.

### **Power-up & Measurement Procedure**

1. Connect input power ( $4.75V < V_{IN} < 5.5V$ ) to VIN test pin.
2. Connect one cell li-ion battery positive and negative terminals to BATT and GND test pin.
3. Pull low to ENB test pin.
4. Verify the LED1 and LED2 whether to light and get charger status.
5. Measure output voltage (approximately 0~4.25V) between BATT and GND.

### **Specification**

Parameter	Symbol	Min	Typ	Max	Units
Battery Voltage Regulation	(CV = 4.25V)	4.186	4.25	4.313	V
	(CV = 4.4V)	4.356	4.4	4.444	
VIN Charge Setting Range	(ISET Mode)	0.9	1	1.1	A
	(USB100)	90	95	100	mA
	(USB500)	380	395	410	mA
Over Voltage Protection	V <sub>OVP</sub>	6.7	6.9	7.1	V

**Schematic, Bill of Materials & Board Layout**

**EVB Schematic Diagram**

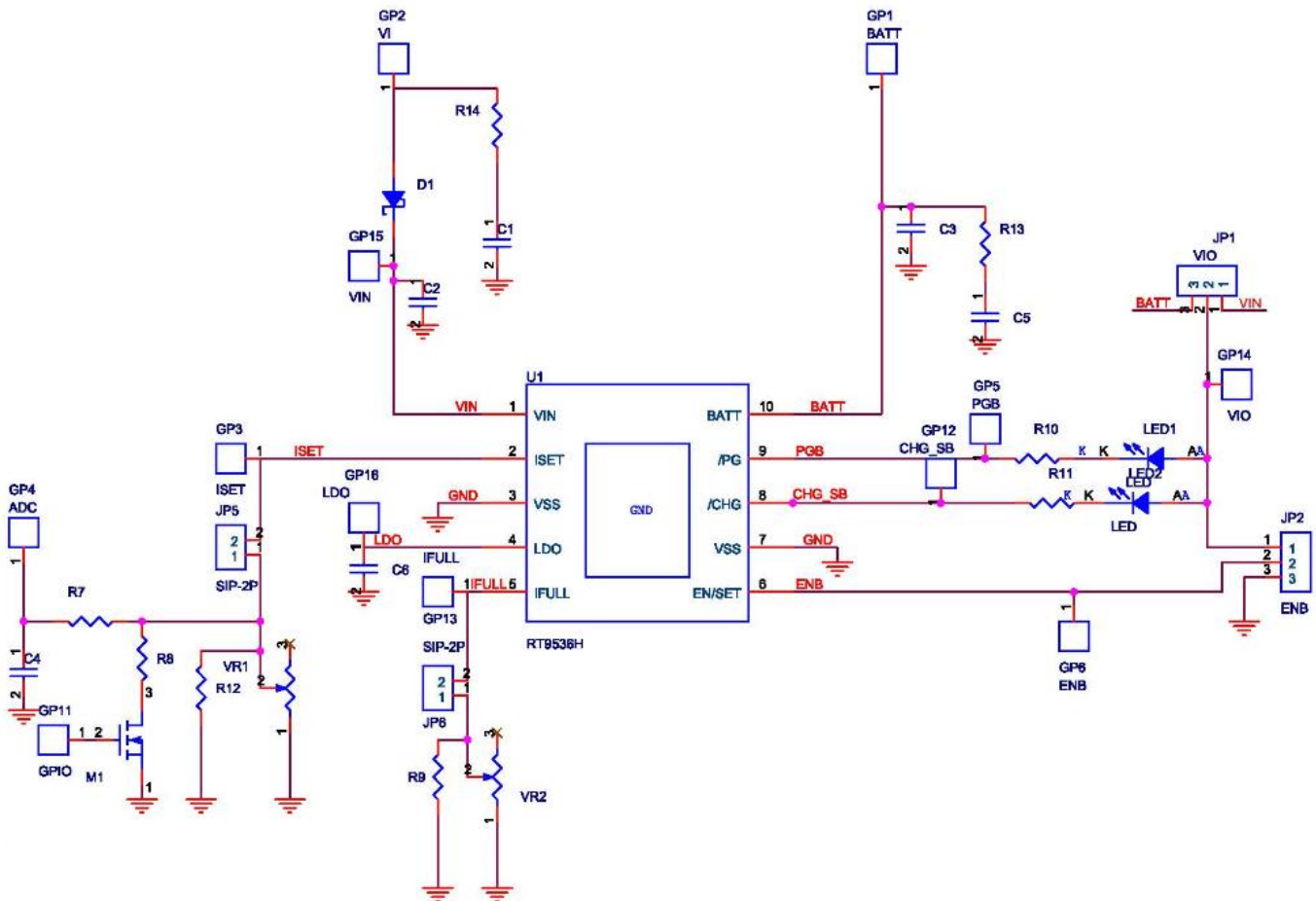

**Bill of Materials**

Reference	Qty	Part Number	Description	Package	Manufacture
U1	1	RT9536HGQW	Battery Charge IC	WDFN-10L 3x2	RICHTEK
C2, C3, C6	3	C0603X5R1E225DT	1 $\mu$ F/25V//X5R	0603	TDK
LED1, LED2	2	DIP LED	LED_Red	DIP	
R10, R11	2	RC0603FR	300 $\Omega$ /0603	0603	YAGEO
VR1, VR2	2		5k $\Omega$ (可變電阻)		
C1, C4, C5, C7	4		NC	0603	
R9, R12, R13, R14	4		NC	0603	
D1, M1	2		NC		

**PCB Layout**

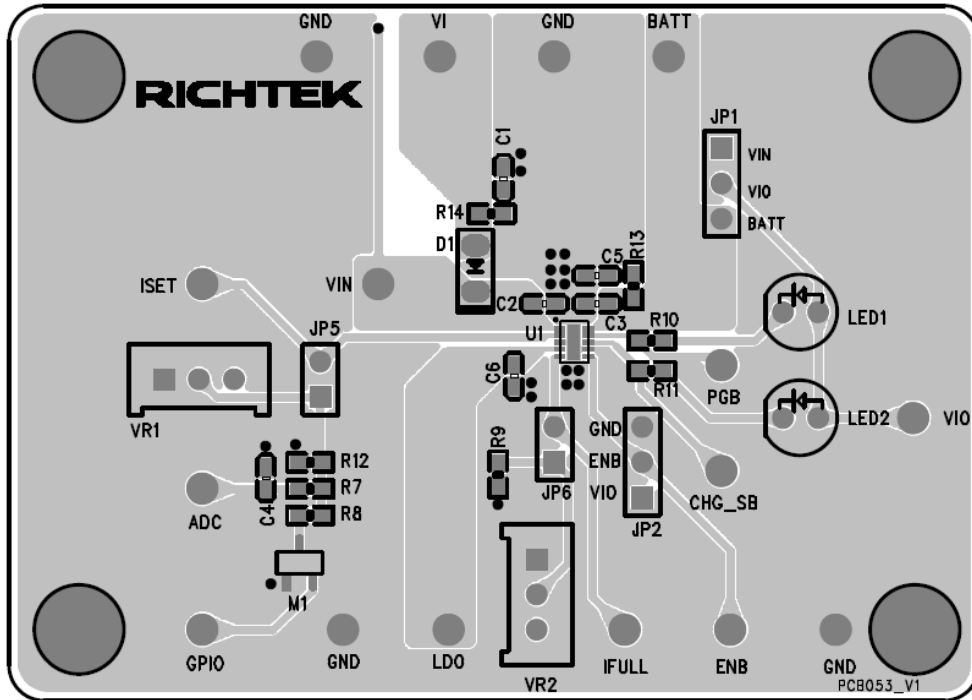

Top View

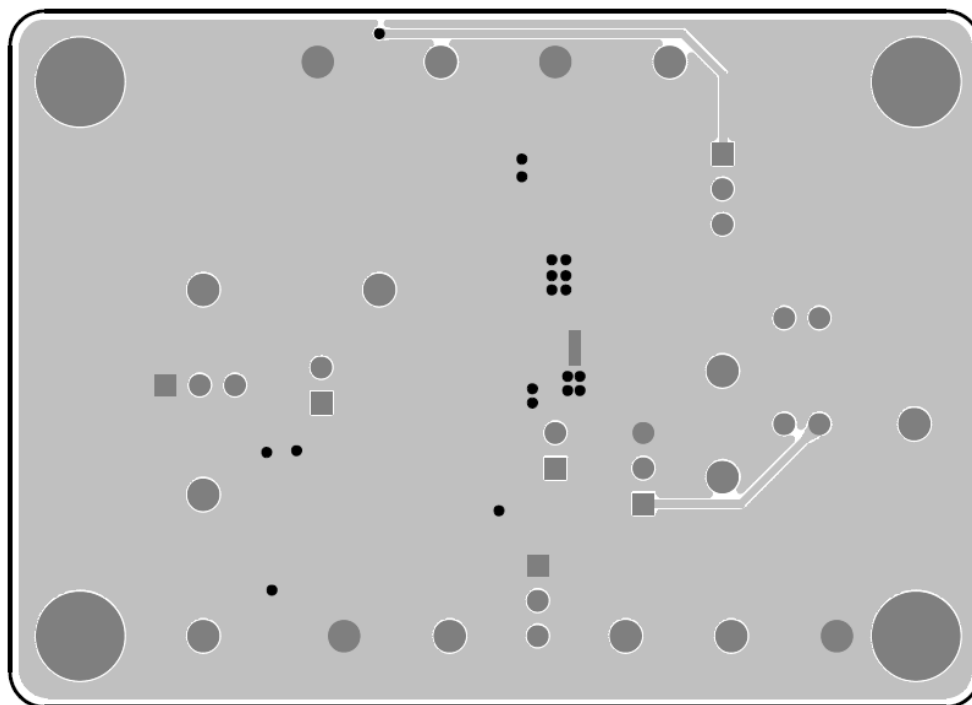

Bottom View

### ***More Information***

For more information, please find the related datasheet or application notes from Richtek website <http://www.richtek.com>.

### ***Important Notice for Richtek Evaluation Board***

THIS DOCUMENT IS FOR REFERENCE ONLY, NOTHING CONTAINED IN THIS DOCUMENT SHALL BE CONSTRUED AS RICHTEK'S WARRANTY, EXPRESS OR IMPLIED, UNDER CONTRACT, TORT OR STATUTORY, WITH RESPECT TO THE PRESENTATION HEREIN. IN NO EVENT SHALL RICHTEK BE LIABLE TO BUYER OR USER FOR ANY AND ALL DAMAGES INCLUDING WITHOUT LIMITATION TO DIRECT, INDIRECT, SPECIAL, PUNITIVE OR CONSEQUENTIAL DAMAGES.